

SUI Desk Chair



Product Sheet — 2025

+Halle[®]

For the SUI Desk Chair, London-based studio Raw Edges has looked to the dynamic nature of production in public spaces.

The inviting armchair is enlivened with a swivel and an embracing wooden surface, creating an intriguing niche with its hybrid, multi-purpose use.

When seated, every aspect of the object evokes free movement, with refined yet generous angles, opening for a wide welcome yet private sphere. SUI typifies elegance in a seat made to serve your liking, enhancing any space with the perfect comfort of on-the-go productivity.

Description

For the modern urban dweller, being productive doesn't necessarily mean that you are sitting at your usual desk. But doing work in lounge spaces without any surface is a recipe for a common struggle. For London-based design studio Raw Edges — known for playful and dynamic public furniture — the trick is a welcoming armchair, beneficial to productivity while using elegance to create an autonomous place to sit.

'Our third Annual Briefing on the theme of Producing proposed a series of interesting relationships: between productivity and wellbeing, productivity and distraction and between shifts of production throughout the day. It is in weaving these multiple behaviours that Sui comes to represent a new take on individual space, a chair where you are encouraged to switch pace intellectually,' says Martin Halle, creative director at +Halle.

'We were immediately intrigued by the notion of combining wellbeing and productivity: a relationship that brought us to an extended armchair, with generous armrests that function as a table, communicating comfort at first sight,' says Yael Mer at Raw Edges and continues: 'Sometimes when I am at my desk, I sit in the same position for three hours, and I find it unhealthy. Here you have a piece of furniture that gives you a lot of space to manoeuvre and change, introducing a personal flow to your day.'

There comes a point in the public realm where private spaces become essential. Sui is that personal seat, but as opposed to a closed-off station, the armchair is conversational, designed with independence and dignity in mind. A swivel element works wonders for the bond between the relaxed and the switched-on. Demonstrating good workspace design, though a swift movement from side to side, or front to back. 'It's such a great gesture, being able to turn 360 degrees. One might think of the swivel mechanism as a minor element, but it nudges you to use the full surface around you,' Shay Alkalay, designer at Raw Edges, explains.

Raw Edges took inspiration from the airport lounges of the world when thinking about how to best serve productivity in a public setting. Like a good lounge, the seat needed to be well-designed, welcoming and provide a comfortable space for eating, drinking, reading, writing and occasional watching or tuning in. The ambition was therefore to create a less prescribed seat, one that people would be keen to use freely, perfectly balancing being public-facing and private.

'In my mind, it has always been a seat designed for momentary productivity because we imagined it in a place where people were on the move. But having said that, I now work on Sui at our studio space in London for whole days and I am always very comfortable. Using the seat regularly, opened up for imagining the armchair in offices, libraries, hotels and conference halls, where people tend to stay for longer,' Alkalay adds.

'When we shared the first images of the prototype, we received comments on Sui as a space saver. Together as a team, we were surprised, as we all thought of her as a sturdy public seat. But when hearing the feedback, it was apparent that Sui is one of these objects, that suits multiple needs, and saves space when she must,' Halle recalls.

It's a real challenge to create furniture that facilitates productivity and still carries the right atmosphere for hospitality. Thankfully, with Raw Edges ability to bring known elements together in a new way, we have a clever seat, adhering to our society's increasing need for adaptability. 'We borrowed elements from the common workstation and came up with a different way of interpreting the components of comfort,' Alkalay says and continues: 'In doing so, you think that you will have to compromise on something — maybe the desk is not big enough, because it's not a desk, it's a surface — but then, we worked at it for long periods at a time, and really, it was perfect, I did not feel that we were compromising at all,' Alkalay recalls.

Sui is minimal and individual in a warm, convivial way. Friendly details opens-up and add refinement, bringing life to the combination of sturdy metal legs, a swivelling fabric seat, and a tactile wooden surface. 'It is the contrast between a bulky frame and the light movement, that gives you the freedom to explore and find your personal position,' Mer reflects. 'Sui is about individuality, constantly answering to recreational and productive behaviours in a way that makes you feel like you are gazing into the future,' Halle concludes.

Designed by Raw Edges Design Studio

London based design studio, Raw Edges is steadfast in its allegiance to colour, pattern, and movement. The intuitive and speculative nature of Raw Edge's practise is anchored in an intriguing sense of imagination. 'The ideas of energy and provocative illusion are aimed at bringing out the kid in all of us who engage with it,' the creative pair says about their experiments. And it is particularly Raw Edge's ability to keep open and serendipitous that makes the duo a perfect collaborator for +Halle's Annual Brief on Producing.

Specifications

MODELS:	WIDTH:	DEPTH:	HEIGHT:	SEATING HEIGHT:
Sui	1279 cm	975 cm	767 cm	43,5 cm

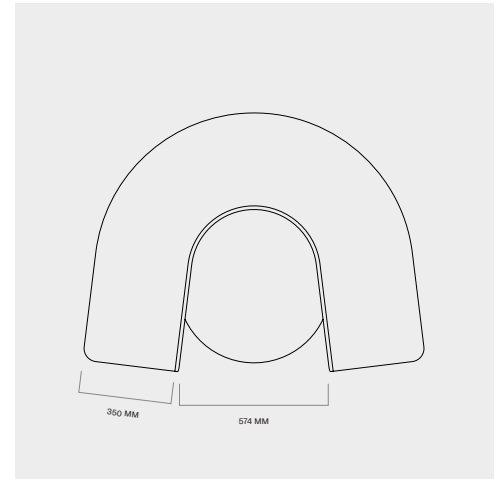
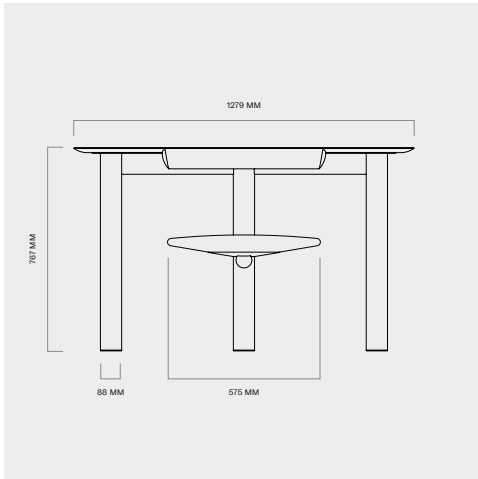

Materials

Table top:	Powder Coated Steel
Swivel seat:	Upholstered Plywood/foam
Base:	Coated Steel

—→ Learn more about the this product and download assets
<https://plushalle.com/products/sui/>



+Halle A/S
Europa Plads 16, 3rd DK-8000 Aarhus C
+45 70 26 66 04
info@plushalle.dk

www.plushalle.com

+Halle[®]