

SCENE Bench System 740 / 1220



Product sheet — 29012024

+Halle[®]

The SCENE Bench System is furniture that adapts to its environment, creating seamless transitions between hard and soft public spaces. Developed by London-based design studio Industrial Facility in response to the Annual Briefing on ‘defining’, SCENE offers new ways for us to focus or unwind.

The modular bench units come with a variety of backrests, offering people either a space to be private, a comfy place to meet, or a semi-private moment to watch the world go by. It’s this multifunctionality that makes SCENE the perfect bridge between sometimes very different architectural spaces.

The system consists of two islands and 3 modules: Center, End and Angle.
All modules comes in two different widths (700mm and 1220mm).

Designed by Industrial Facility

London-based studio Industrial Facility was co-founded in 2002 by designers Sam Hecht and Kim Colin. Their approach reflects both a thoughtful consideration of form and a unique understanding of contemporary life, creating beauty out of utility in the products, furniture and exhibitions they design. Hecht, from London, trained as an industrial designer, while Colin, from Los Angeles, trained as an architect; together they have helped clients to produce projects that display an understanding of cultural relevance and commercial success.

SCENE Island 740

MODEL:	LENGTH:	WIDTH:	HEIGHT:
Base module 1220	2100 mm	740 mm	455 mm
Low back	730 mm	566 mm	330 mm
High back	890 mm	592 mm	780 mm

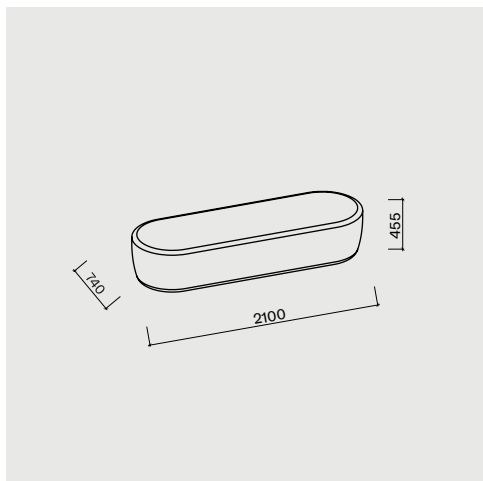

Base module

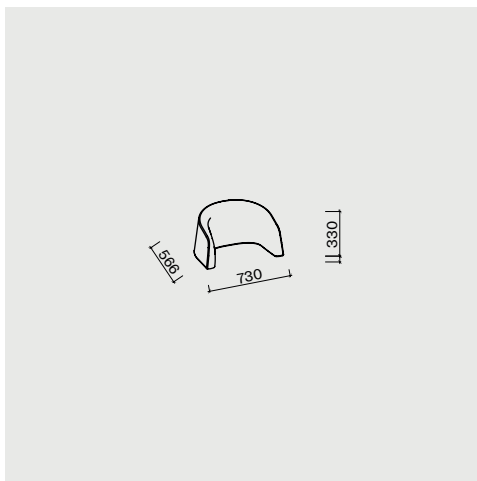

Low back

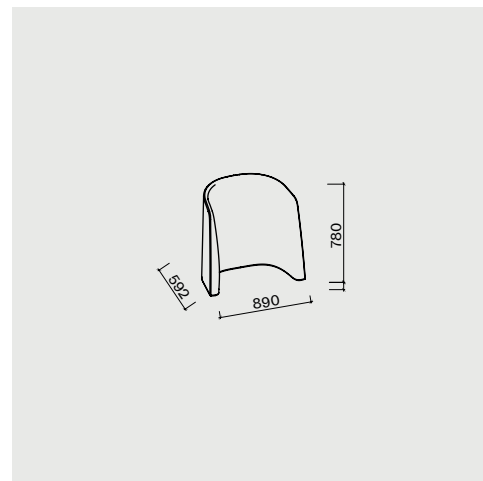

High back

Placements of seats

● Low back ● High back

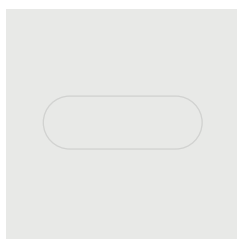

Island 740 v1

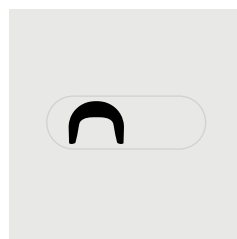

Island 740 v2

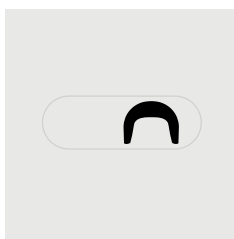

Island 740 v3

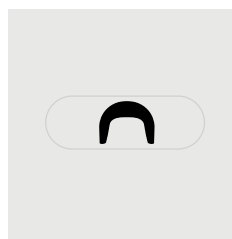

Island 740 v4

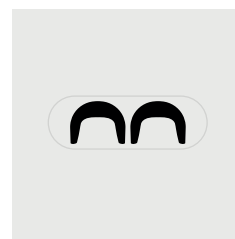

Island 740 v5

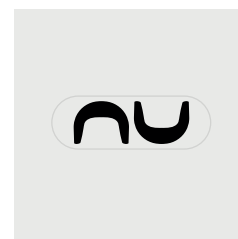

Island 740 v6

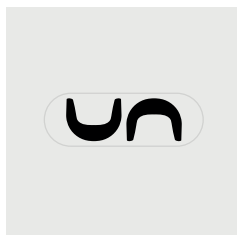

Island 740 v7

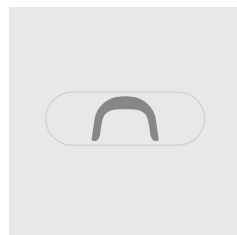

Island 740 v8

SCENE Island 700

Examples of configurations



SCENE Island 1220

MODEL:	LENGTH:	WIDTH:	HEIGHT:
Base module 1220	2100 mm	1220 mm	455 mm
Low back	730 mm	566 mm	330 mm
High back	890 mm	592 mm	780 mm

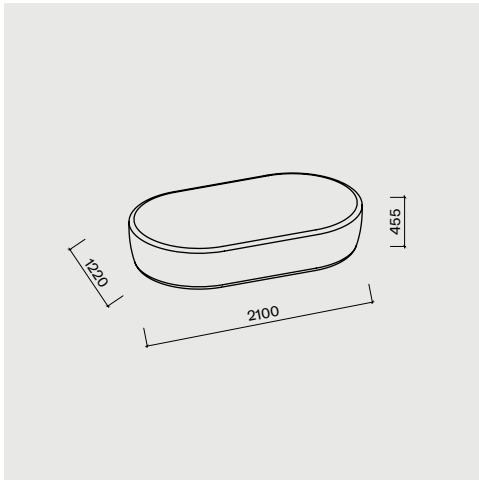

Base module

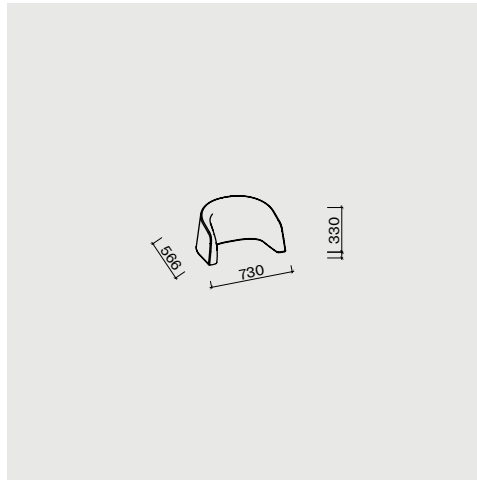

Low back

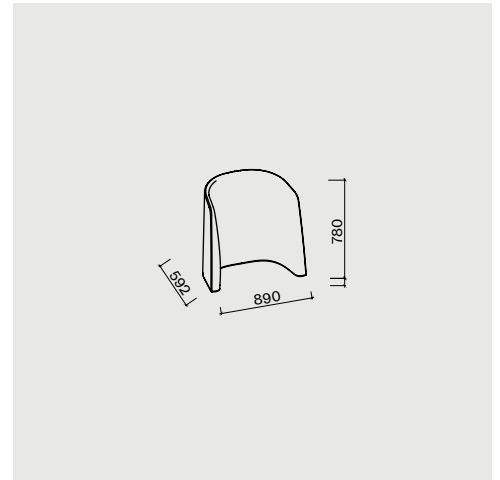

High back

Placements of seats

● Low back ● High back

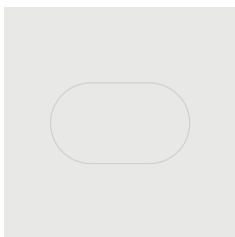

Island 1220 v1

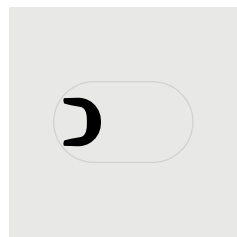

Island 1220 v2

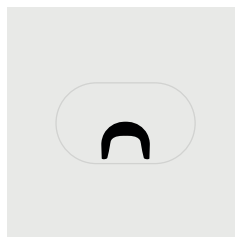

Island 1220 v3

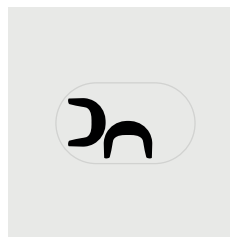

Island 1220 v4

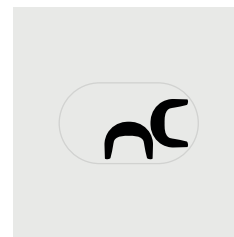

Island 1220 v5

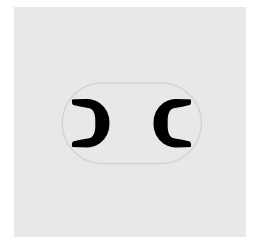

Island 1220 v6



Island 1220 v7

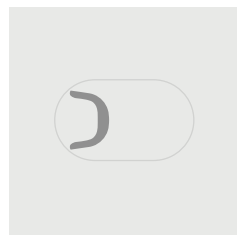

Island 1220 v8

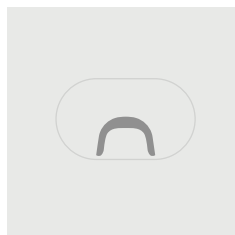

Island 1220 v9

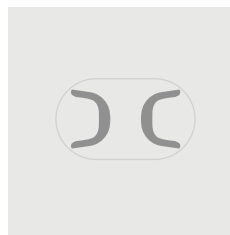

Island 1220 v10



Island 1220 v11

SCENE Island 1220

Examples of configurations

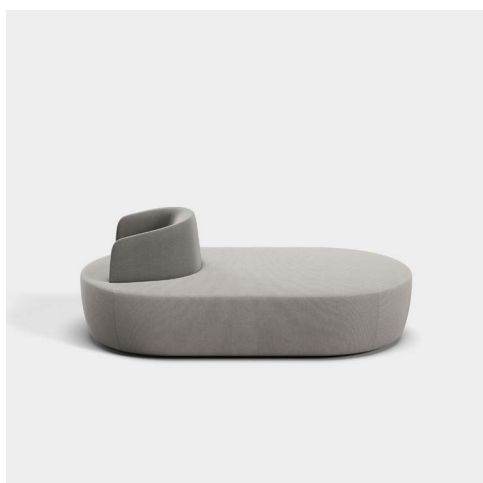

SCENE modules 740

MODEL:	LENGTH:	WIDTH:	HEIGHT:
End module 700	1605 mm	740 mm	455 mm
Center module 700	1800 mm	740 mm	330 mm
Angle module 700	45°	740 mm	780 mm
Low back	730 mm	566 mm	330 mm
High back	890 mm	592 mm	780 mm

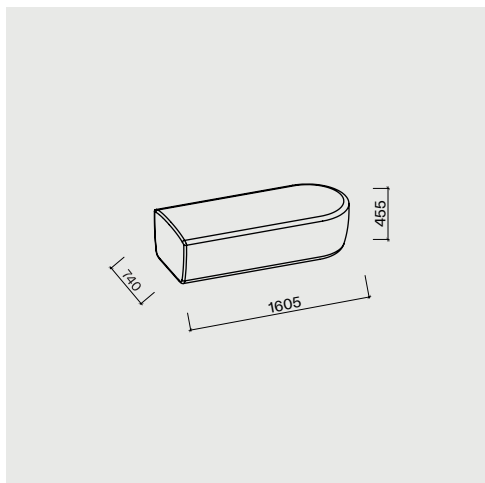

End module

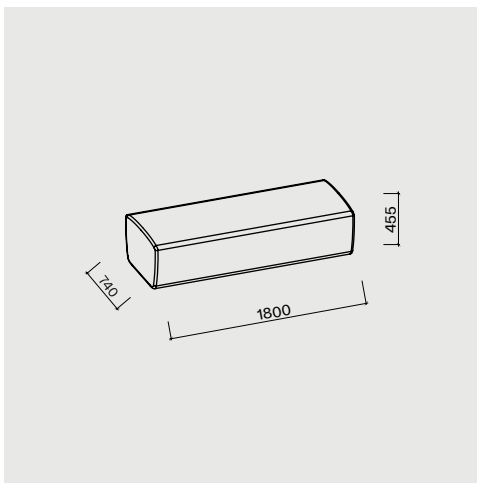

Center module

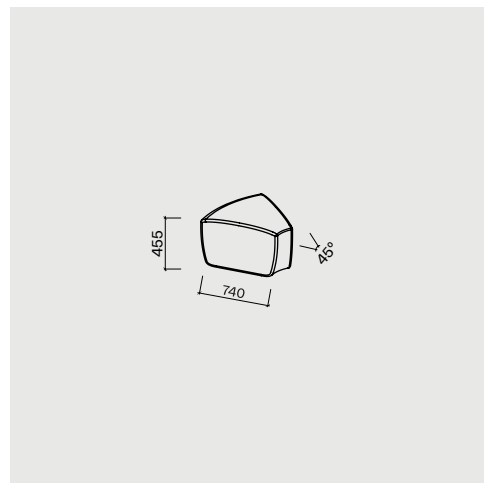

Angle module

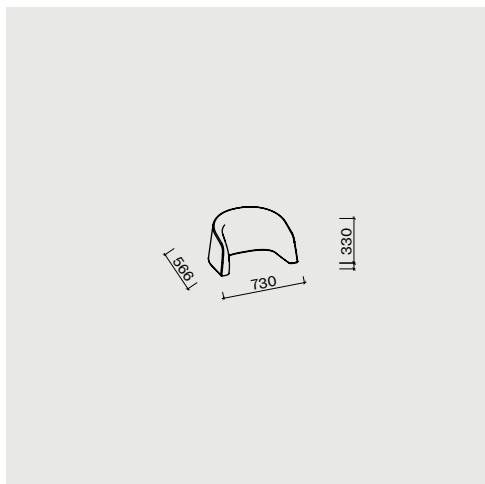

Low back

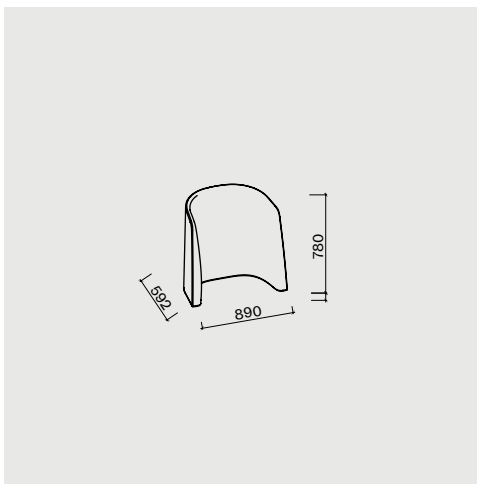

Tall back

SCENE modules 700

Building blocks

● Low back ● High back

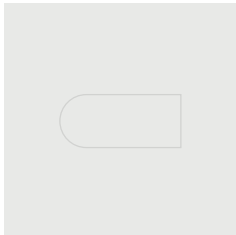

740 End v1

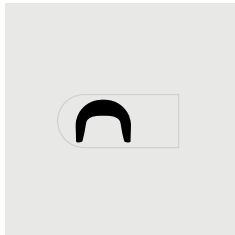

740 End v2



740 End v3

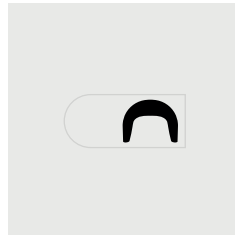

740 End v4

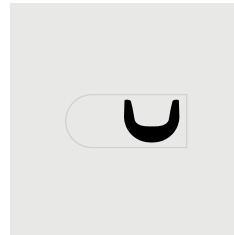

740 End v5



740 End v6

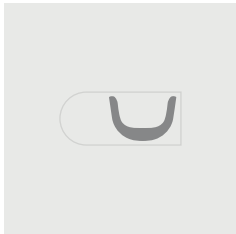

740 End v7

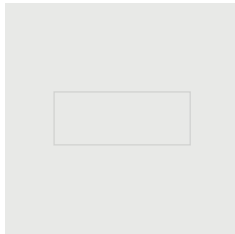

740 Center v1

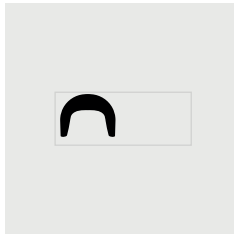

740 Center v2



740 Center v3



740 Center v4



740 Center v5

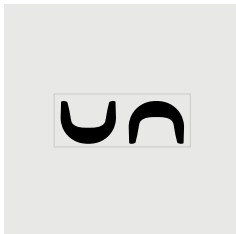

740 Center v6

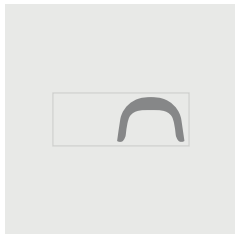

740 Center v7



740 Center v8

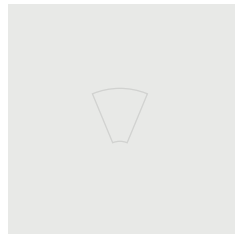

740 Angle v1

SCENE modules 740

Examples of configurations



SCENE modules 1220

MODEL:	LENGTH:	WIDTH:	HEIGHT:
End module 1220	1605 mm	1220 mm	455 mm
Center module 1220	1800 mm	1220 mm	330 mm
Angle module 1220	45°	1220 mm	780 mm
Low back	730 mm	566 mm	330 mm
High back	890 mm	592 mm	780 mm

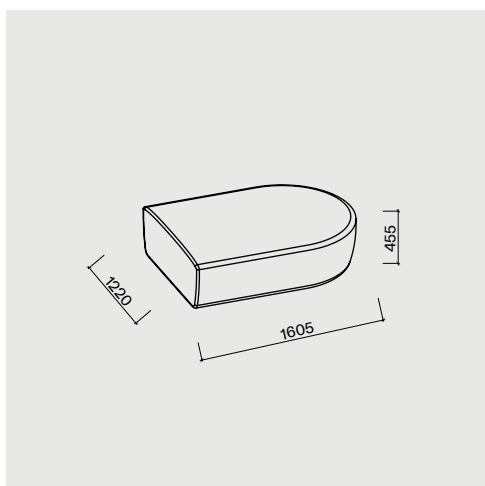

End module

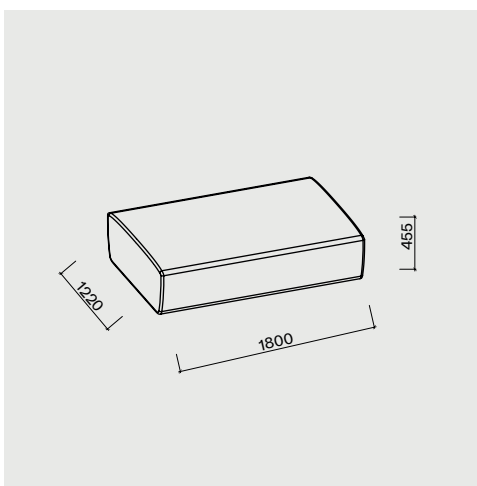

Center module

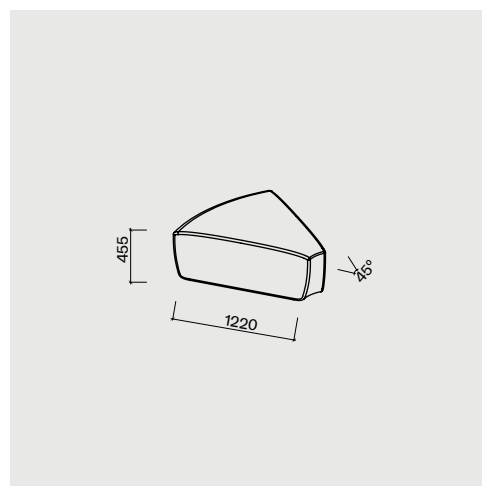

Angle module

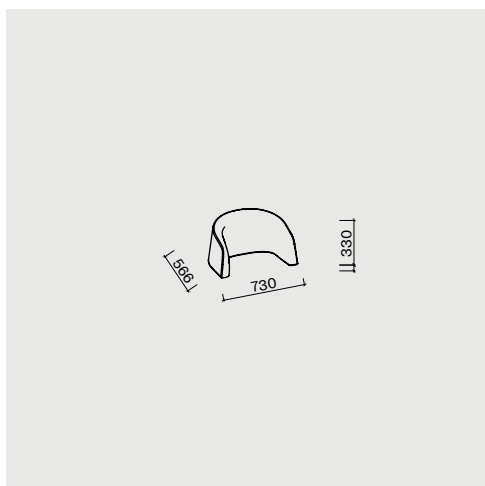

Low back

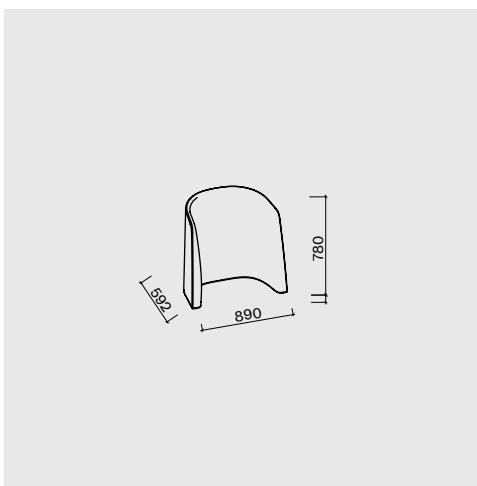

Tall back

SCENE modules 1220

Building blocks

● Low back ● High back

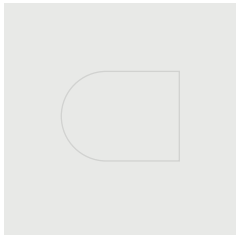

1220 End v1

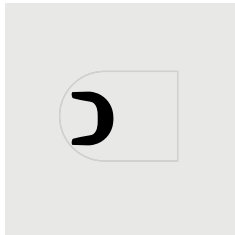

1220 End v2

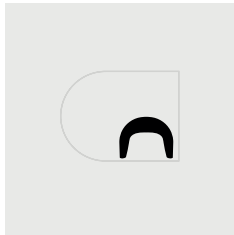

1220 End v3

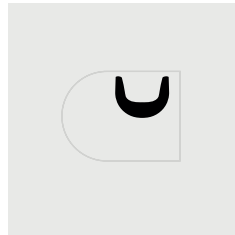

1220 End v4

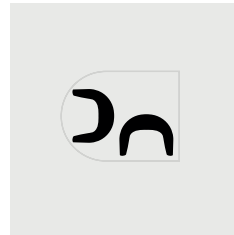

1220 End v5



1220 End v6

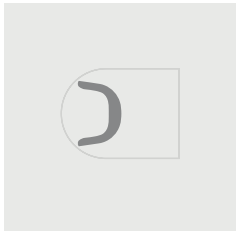

1220 End v7

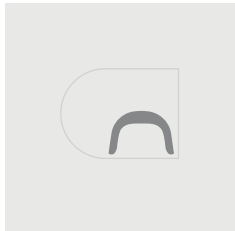

1220 End v8

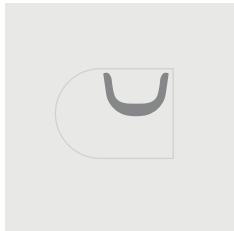

1220 End v9

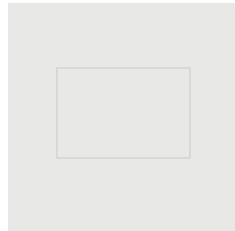

1220 Center v1

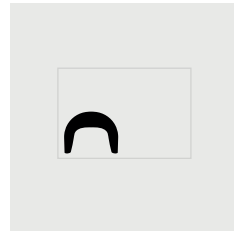

1220 Center v2

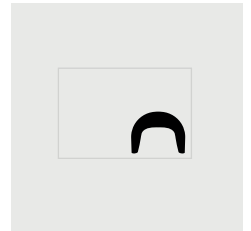

1220 Center v3



1220 Center v4

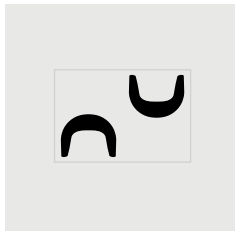

1220 Center v5

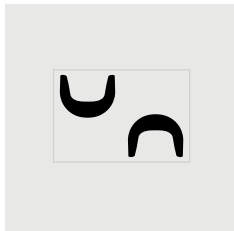

1220 Center v6

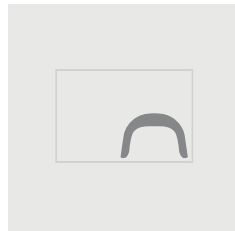

1220 Center v7



1220 Center v8

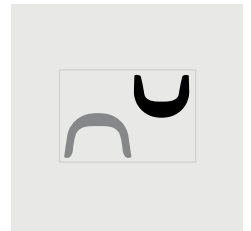

1220 Center v9

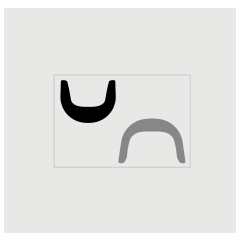

1220 Center v10



1220 Angle v1

SCENE modules 1220

Examples of configurations



+Halle® Production

+Halle® factory in Vinderup, Denmark



Factory runs on renewable energy



Highest Danish environmental standards



FSC® certified
 REACH compliant
 No BFRs
 No PVC
 Anti allergen
 Oeko Tex Standards

+Halle® production

All +Halle products are made according to the highest Danish environmental standards. The wood is grown with respect for the land, all foam and fabric are developed and tested with compliance to Scandinavian standards. Our factories also take great pride in following the Danish working environment act, reassuring all artisans being happy and safe at all times.

FSC® certification



Preferred by Nature - NEPCON OÜ hereby confirms that the Chain of Custody system of: +Halle A/S, Europaplads 16, 8000 Aarhus, Denmark has been assessed and certified as meeting the requirements of FSC-STD-40-004 V3-1; FSC-STD-50-001 V2-1 EN

Scope of certificate

Certificate type: Single Chain of Custody
 Certificate registration code: NC-COC-064696
 FSC® License Code: FSC-C163859

A specific list of which of our products that are FSC® certified is available upon request.

Interview

Our space

Soft seating areas often result in many pieces of furniture of different colours and shapes fighting to fit together in the awkward corners of our public spaces.

As an answer to this, the Scene collection enables people to define their own ways of coming together in a variety of situations, and in an elegant, clean, and effortless way. Scene inspires an immediate sense of privacy, semi-privacy, and social space in an overarching harmony with the environment around you.

Defining is all about context

“During the annual briefing on ‘defining’, which took place in isolation during the pandemic, we had a very fruitful discussion around the idea of ownership in the public realm, how much privacy and distance an individual needs versus how much you are drawn to participating in a group or social space, even from afar.

For instance, we looked at opportunities of remaining private, but still allowing for a more social interpretation. Such dialogues helped us draw up the criteria for how we can possibly come to define public seating in the future,” says Martin Halle, creative director at +Halle.

Let’s put our heads together

“For a while, we have had the notion of a ‘third space’ – if the home was the first and the office was the second, the third space acted as the in-between where people can meet to discuss freely. But today, the third space is becoming the second, an informal space, where you want to be creative, relying on other people, stimulation, interaction, and conversation.

I think Scene carries this multiplicity, providing a solution for these things to take place outside of the home, says Sam Hecht, co-founder at Industrial Facility.”

Freedom of choice

Industrial Facility’s interpretation of the theme ‘defining’ was to create a seat whose diverse functionality was intuitive. “Scene is giving the individual a choice. You can choose your seat and your position within one piece of furniture as supposed to having to choose one area, over another. You can be with a colleague and have two different ways of sitting, or you can have a whole group facing their colleagues in another area.

In a way, the collection remains an experiment in defining, leaving the community to create their own ways,” Kim Colin co-founder of Industrial Facility, explains.

Distance versus closeness

During the pandemic, we all had to learn about distancing and the measures made their way into the collection, in an unavoidable way. But interestingly, it also caused a rebellious characteristic: “We always knew it was a bench, and the daring thing about a bench is that it’s a great democratizer as it will always remain open for use, a space available to sit as you like, even without a back that is defined for it. We always saw the potential of sitting close, even if the times were different back then,” Colin reflects.

Separate from the herd

“Scene is bringing different pieces of furniture together onto one structure, pieces that would previously have been like stray animals, which tend to all move around,” says Colin. “With Scene, you never have that sense, because the piece is a collector of many seats, giving a settling home to the many, without the mess.”

“The problem we are having with lounge spaces today is that there is this tendency to throw sofas at the problem, and so you end up with more and more of these soft pieces of furniture in the hope that it can provide a signal to come and sit down, converse and collaborate. It just does not work like that, because they often end up as dysfunctional showrooms. What we are trying to do with +Halle is a little bit more purposeful, building a scene that has a multiplicity to it without overwhelming the space,” says Hecht.

Scene setting

With the Scene collection, you have a variety of modules to choose from, with a range of lengths as well as angled configurations. With its elegant structure and simplicity of form, Scene can become a place of vantage as well as a pure function. “When you sit on the Scene you are looking out, it’s making a view to various areas, providing a montage, or series of scenes if you like,” Halle concludes.

—> Learn more about the SCENE Bench System and download assets
<https://plushalle.com/>



+Halle A/S
Europa Plads 16, 3rd DK-8000 Aarhus C
+45 70 26 66 04
info@plushalle.dk
www.plushalle.com

+Halle®